

Burton Duo

Fingerprint Lock

ScanLogic Basic
FPC-1808-II (VdS)

**To be used with locks
EL-0601, EL-0701, EL-0901**

Specifications

Rated voltage: DC 9V

Working temperature: -25° ~ 60°

Humidity during use: <90%.

Code length: 6 digits

Only suitable for indoor use

Safe locks certified in accordance with EN1300 are not permitted to be opened by fingerprints only (without additional code entry).

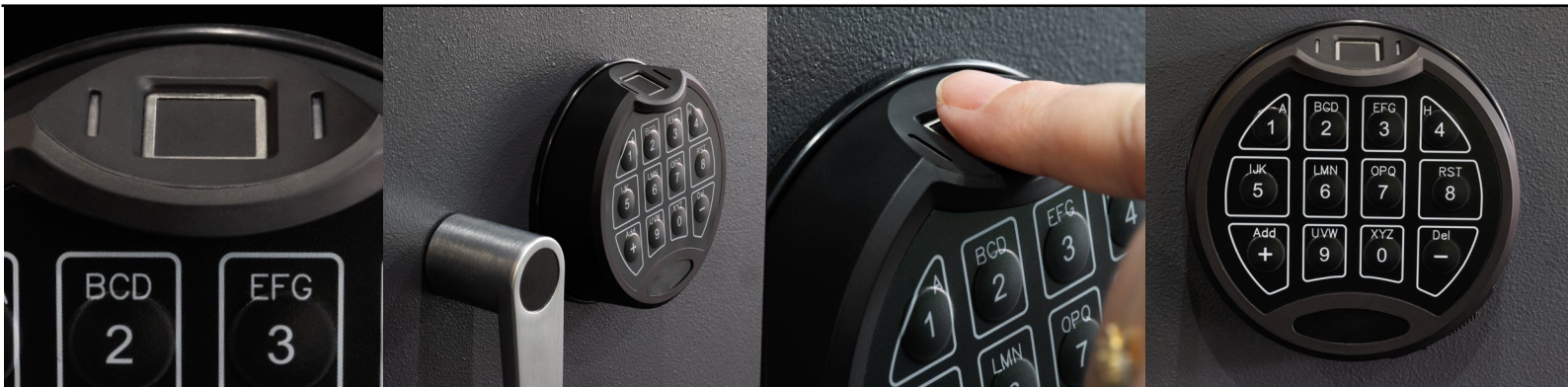

Important

- Always carry out programming when the lock is open and safe door is open.
- Before closing the safe door, make sure that all the programming is correct.
- Check a new code at least 3 times before closing and locking the door to ensure that the code has been changed correctly.
- The system does not allow the master code, the manager code, and the user code to be set at six zeros (0-0-0-0-0-0) or six nines (9-9-9-9-9-9).
- To save battery power, the system switches to standby mode if no button is pressed within 10 seconds. Standby mode is indicated by two short beeps. Input processes that have not yet been completed must be repeated completely.
- Do not allow your personal code to be spied on. When entering the code, always cover the keypad as well as possible so that no one can see which numeric key you are pressing.

Low Voltage Indicator

After opening, the input unit may indicate that the battery voltage is too low by flashing and beeping several times.



The battery is very low, nearly empty and must be replaced with a new one immediately

Change Battery

There is a pull-out compartment for a 9V battery on the bottom of the input unit.



We recommend using Energizer™ or Duracell™ 9V ALKALINE batteries.

To replace the battery, pull out the battery compartment first.

- 1 Open the battery compartment latch.
See Fig. 1.
- 2 Pull out the battery compartment.
See Fig. 2.
- 3 Remove the battery and replace it with a new one.

Make sure that you place the new battery in correctly. The positive (+) and the negative (-) contact must be in the correct position.

See Fig. 3.

- 4 Reinsert the battery compartment into the input unit and slide it up until the cover rests against the input unit. Press the battery compartment latch until it is firmly and securely in place.

See Fig. 4.



Fig. 1

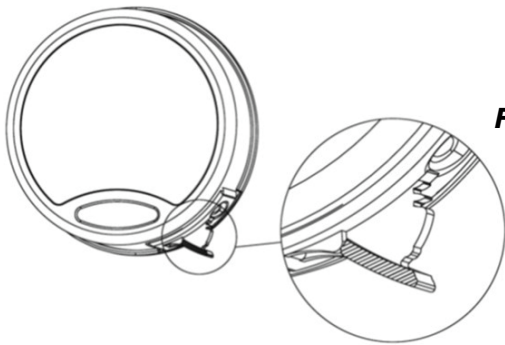
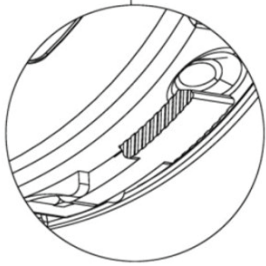

Fig. 2

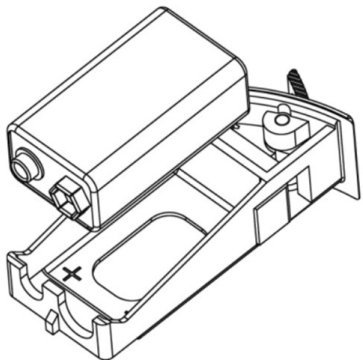

Fig. 3



Fig. 4

A Open the lock

- 1) Enter default factory Manager-Code
1-2-3-4-5-6

B Forgotten Code Guarantee



For safety reasons, we have programmed the lock with its own unique reset code and provide a support service for the length of your warranty.

The unique reset code guarantee provides secure storage and support should you need to reset your lock in the future.

For further information regarding your lock or for support please contact us at

enquiries@burtonsafes.co.uk.

- * *The Reset-Code cannot open the lock.*

C Change manager code

- 1) Enter 0-0-0-0-0-0
- 2) Enter existing code, 1 beep
- 3) Enter new 6-digit code, 1 beep
- 4) Repetition of the new 6-digit code, 2 beeps

- * *1 long beep means that the code is not allowed, or the identical code was not entered for repetition. Repeat steps 1 to 4.*

- ** *For security reasons, we recommend changing the Manager-Code immediately after the lock is put into operation.*

- *** *The default Manager-Code 1-2-3-4-5-6 must be changed before other users can be added.*

D Adding the manager's fingerprints

- 1) Open with Manager-Code/fingerprint
- 2) Press and hold "+", 1 beep
- 3) Place a fingerprint 4 times onto the fingerprint reader, remove your finger after each single (1) beep
- 4) After reading your finger 4 times you will hear 2 beeps to confirm the addition of the fingerprint

- * *The Manager-Code can add up to 5 fingerprints*

E Add User-Code (up to two User-Codes can be added)

- 1) Open with Manager-Code/fingerprint
- 2) Press and hold "1", 1 beep
- 3) Enter new 6-digit code, 1 beep
- 4) Repetition of the new 6-digit code, 2 beeps

F Add Fingerprints

- 1) Opening with own User-Code/fingerprint
- 2) Press and hold "+", 1 beep

- 3) Place a fingerprint 4 times onto the fingerprint reader, remove your finger after each single (1) beep
 - 4) 2 beeps confirm the addition of the fingerprint
- * *Each User-Code can add up to 5 fingerprints.*

G Delete all users

- 1) Open with Manager-Code/fingerprint
- 2) Press and hold "3", 2 beeps

- * *All User-Codes have been deleted.*

- ** *The Manager-Code/fingerprints do not change.*

H Reset lock

(deletes the User-Codes, all fingerprints and resets the Manager Code to the default factory setting)

- 1) Refer to section B.
- 2) Contact our office for support.

I Switch off beeper

- 1) Open with Manager or user code/fingerprint
- 2) Press and hold "4", 1 beep

J Switch on beeper

- 1) Open with Manager or user code/fingerprint
- 2) Press and hold "4", 2 beeps

K Security levels

Security level 1 = Code **only** (default factory setting)
Security level 2 = Fingerprint **and** code

Change to security level 1 (code only)

- 1) Open with Manager or user code and fingerprint
- 2) Press and hold "5", 1 beep, followed by 1 beeps

Change to security level 2 (fingerprint and code)

- 1) Open with Manager or user code
- 2) Press and hold "5", 1 beep, followed by 2 beeps.

L Penalty time after four invalid code entries



Entering four (4) consecutive invalid codes will result in a penalty period of 5 minutes)

- 1) The unit beeps at 5-second intervals to indicate that it is in penalty time.
- 2) While the system is in penalty time, the buttons do not respond.
- 3) The penalty time is only interrupted by removing the battery, not shortened, or deleted. After reinserting the battery, the penalty time will continue until the 5 minutes have elapsed.
- 4) End of locking/penalty time - 1 long and 2 short beeps
- 5) Two (2) consecutive incorrect entries result in a further penalty period of 5 minutes.
- 6) A correct code entry interrupts the penalty sequence. Entering four (4) consecutive invalid codes will result in a penalty period of 5 minutes.



5 Year
Extended
Warranty



All our safes come with a 2 year warranty as standard. Consumers can Register on-line to increase the warranty to 5 years where products show the 5 Year Consumer Warranty badge.

Security Safes displaying the Home series Safe For Longer free replacement badge benefit from the 5 year warranty and a free replacement in the event of burglary.

*Ts & Cs apply, visit our website for full details

Please register online to qualify for the additional warranty at www.burtonsafes.co.uk



Secure Your Valuables with a Burton Safe

www.burtonsafes.co.uk | +44 (0) 1484 663388 | enquiries@burtonsafes.co.uk
Brockholes Business Park, Rock Mill Road, Holmfirth, HD9 7BN



THE SURE DEFENCE